



oceania
SOLUTIONS GROUP

Double Skin FCU Series

Technical IOM Manual



euroclima®



Your projects, challenges and requirements are our focus. We have a dedicated team that can engineer tailored solutions for your commercial HVAC application.

Oceania Solutions Group is an Australian owned business that focuses on providing engineered HVAC solutions. We value the importance of relationships with our clients and partners. Our team enjoy collaborating and solving complex 'design and construct' projects for your business with our product solutions.

Oceania Solutions Group are proud of our extensive portfolio and experience within HVAC industry. From industrial applications through to commercial air conditioning installations for tropical and high humidity environments.

Operating throughout Australia, New Zealand and the South Pacific Islands, we provide engineered technical data and commercial support for a wide range of HVAC solutions.

Our experienced team of HVAC professionals work hand-in-hand with market leading suppliers of HVAC solutions and equipment.

With international accreditation from Eurovent, CTI, AHRI, TÜV and AMCA, our products are rigorously tested and certified, meeting Australian and New Zealand standards and regulations.

Partnering with trusted international suppliers, we are available to provide an engineered solution for your next project.

Contents

Company overview	04
Product technical data	05
General information	06
Important notes	07
Installation	08
Electrical connections general rules	11
Dimensional drawings - under ceiling unit	13
Dimensional drawings - floor mounted unit	14
Connections	15



Better air since 1963

Euroclima is a company with extensive international operations, four manufacturing facilities in Italy, Austria and India and more than 34,000 m² of production and offices. Euroclima specialise in the manufacturing and worldwide distribution of air handling units and fan coil units.

Euroclima has a well distributed network of sales and service across Europe, Asia, Middle East and Northern Africa. Our partners in various countries assume a surface covering responsibility for marketing, local servicing and optimal assistance.

The #1 partner for fan coil units

Euroclima offers a wide range of standardised and customised terminal units for residential and commercial buildings: hotels, offices, schools, stores and hospitals to name a few.

From simple, cost effective products for comfort applications, to specialised equipment such as double skin fan coils for marine or medical applications. Euroclima can provide you the right terminal units to meet your exact needs. Specialised products can be designed for individual projects with components such as EC motors or UVC lamps. All Euroclima terminals can be equipped with factory mounted controls.



Ducted Fan Coil Units

Euroclima have an extensive range of ducted fan coil units that provide an optimal solution for shopping centres, schools and universities, hotels, apartments and offices for summer cooling and winter heating.

The units are single and double skin casing, with optional filters and frames, three speed AC fan and 0-10V EC fan solutions for optimal air distribution, complete with a high efficiency heat exchanger, drain pans and a wide range of controllers and value train inclusions for additional pricing to suit your project requirements.

Product warranty

The Euroclima ducted fan coil units, chilled and hot water units are supplied with a parts warranty for either 12 months from start-up or 16 months from invoice date, whichever is to occur first.

A parts and labour warranty can be obtained at the time of purchasing the units. Please contact your local Oceania Solutions Group representative for further details.

Technical data

AC Fans

Technical Data					Cooling		Conditions			Heating		
Unit	Model	Pipes	Fan Speeds	Flow (l/s)	Total (kW)	Sensible (kW)	Air On (DB °C)	Air On (WB °C)	Air Off (DB°C)	Total (kW)	Static Pa	Sound Lp (dBa)
TB-DS	10/5R	4T	5	281	8.94	5.57	27	19.5	9.5	6.19	150	43.6
TB-DS	11/5R	4T	5	335	10.21	6.62	27	19.5	10	6.88	150	43.3
TB-DS	22/5R	4T	5	563	18.11	11.54	27	19.5	9.3	12.48	150	46.5
TB-DS	23/5R	4T	5	644	20.21	12.94	27	19.5	9.7	13.54	150	46.3
TB-DS	31/5R	4T	5	759	24.42	15.56	27	19.5	9.3	16.83	150	47.6
TB-DS	32/5R	4T	5	937	29.07	18.52	27	19.5	10	19.03	150	47.3



TB-DS



TH-DS

AC Fans

Technical Data					Cooling		Conditions			Heating		
Unit	Model	Pipes	Fan Speeds	Flow (l/s)	Total (kW)	Sensible (kW)	Air On (DB °C)	Air On (WB °C)	Air Off (DB°C)	Total (kW)	Static Pa	Sound Lp (dBa)
TH-DS	20/4R	4T	3	515	14.02	9.22	27	19.5	11.6	13.45	250	38.7
TH-DS	30/4R	4T	3	925	24.79	15.98	27	19.5	12.1	11.69	250	41.7
TH-DS	50/4R	4T	3	1310	34.63	22.31	27	19.5	12.4	31.55	250	43.7
TH-DS	20/5R	4T	3	515	15.47	10.08	27	19.5	10.1	13.45	250	38.7
TH-DS	30/5R	4T	3	925	27.18	17.59	27	19.5	10.6	11.69	250	41.7
TH-DS	50/5R	4T	3	1310	38.28	24.67	27	19.5	10.8	31.55	250	43.7

Technical data

EC Fans

Technical Data					Cooling		Conditions			Heating		
Unit	Model	Pipes	EC (0-10V)	Flow (l/s)	Total (kw)	Sensible (kw)	Air On (DB °C)	Air On (WB °C)	Air Off (DB °C)	Total (kW)	Static Pa	Sound Lp (dBa)
TE-DS	20/5R	4T	10	743	16.25	11.80	27	19.5	13.3	9.14	250	-
TE-DS	30/5R	4T	10	1205	27.11	19.03	27	19.5	13.4	15.32	250	-
TE-DS	60/5R	4T	10	1963	45.89	30.96	27	19.5	13.4	25.56	250	-
TE-DS	20/6R	4T	10	743	16.25	11.80	27	19.5	13.3	9.14	250	-
TE-DS	30/6R	4T	10	1205	27.11	19.03	27	19.5	13.4	15.32	250	-
TE-DS	60/6R	4T	10	1963	45.89	30.96	27	19.5	13.4	25.56	250	-



TME



EC Fans

Technical Data					Cooling		Conditions			Heating		
Unit	Model	Pipes	EC (0-10V)	Flow (l/s)	Total (kw)	Sensible (kw)	Air On (DB °C)	Air On (WB °C)	Air Off (DB °C)	Velocity (m/s)	Static Pa	Sound Lp (dBa)
TME	035-5R	2T	10	988	24.20	15.92	27	19.5	13.1	2.40	250	-
TME	070-5R	2T	10	1848	46.71	30.41	27	19.5	12.8	2.20	250	-
TME	105-5R	2T	10	2582	67.40	43.44	27	19.5	12.5	2.10	250	-
TME	140-5R	2T	10	3161	82.76	53.56	27	19.5	12.4	2.00	250	-
TME	035-6R	2T	10	988	26.03	17.23	27	19.5	11.9	2.40	250	-
TME	070-6R	2T	10	1848	50.50	33.11	27	19.5	11.6	2.20	250	-
TME	105-6R	2T	10	2582	71.94	46.98	27	19.5	11.3	2.10	250	-
TME	140-6R	2T	10	3161	89.69	58.23	27	19.5	11.1	2.00	250	-



General information

"Draw trough" configurations utilise 4P motors and reach static pressure from 120Pa to 250Pa, in response to customer demand. They are available utilising high efficiency germicide lamps. These lamps not only avoid risk of contamination but also permit relevant energy savings (approx 15%) when maintained with clean heat exchange fins. Industries such as museums, libraries, hotels, medical facilities are all benefiting from using this product.

Air delivery can be ducted and a damper system can be provided for fresh air. The motor speed controller can be wall mounted. An auxiliary drain pan is an available, to be extended below motorised valve kit. Cleanable filters are clipped on air return to be easily dismantled during usual periodic maintenance or can be mounted inside a rigid frame in case of ducted air return.

Finned Coils

Tubes are manufactured from 9.52mm (3/8") OD copper and are staggered for greater heat transfer. High efficiency louvered aluminum fins 10FPI are bonded into the tubes and coils are available for water or for DX version. Water coils includes heavy steel headers screwed gas Female. Standard 2-pipe coils 4-Rows, and an additional 1R heating coils are available for 4 pipe systems, all 10 PFI. Manual drain and manual or automatic air vent applied on prolonged Units are supplied as standard with pipe connections on the right when viewed from the front. Left sided connections are available when specified at order but it is also possible to reverse the handling on site. Water standard coils Pressure: working 14,4 Bar – test 16 Bar. Temperature: working 80°C – max 100°C

Drain Trays

Manufactured from galvanized sheet steel with an epoxy paint finish on both sides. The drain tray is fully insulated with 5 mm closed cell politeness foam which has a class "1" European standard fire proof. Stainless steel drain trays are also possible.

Air Filters

The synthetic media is cleanable and enclosed in a galvanized frame with wire mesh support. Efficiency is to class EU3-G3-M1 th.23 mm. If ducted return air is required, a galvanized filter frame is available with bottom or side filter removal. Are also available washable filters or aluminum mesh.

Fan Deck

The motor (ErP 2015) is mounted directly on beach galvanized scroll, V230/1/50Hz supply, has a permanent coupled capacitor (PSC/AOM), sealed for life sinterized bearings, open aluminum enclosure rated IP55 4Poles Class 'F' and 3 speeds with built in thermal overload protection. Centrifugal fans are fitted on a rigid galvanized panel having galvanized scroll and impeller to ensure a spark free fan in case of accidental contact between fan and scroll.

On-Off and Modulating Valve Kit

Are available with 2 or 3-port valves. They can be supplied loose, or factory fitted, when they are wired and tested. It is also possible to factory fit any other leading brand of controls and these are normally free issued to us from the client. All kits are assembled to allow ease of maintenance and removal.

DS Version

Sandwich panel 25 mm th outside skin sheet steel RAL 9003, 0,7 mm th SP pre-painted corrosion protection, internal skin galvanized sheet steel 1,0 mm th. Insulating material Rockwool, non-combustible, fire class A1 20 kg/m³ Rw 31 dB (Rw: Sound Transmission Loss).

Optional Accessories



Elec digital thermostats



Actuators 0-10v and on/off



2-3 way chilled water valves and bypass



Condensate pump

Important notes

Warning: the manufacturer and supplier are not responsible for the incorrect installation of hydraulic and electrical connections.

Please carefully read this manual before installing and operating the HW series fan coil unit. It is recommended this manual is kept readily available and referred to for additional information about the unit, operation and maintenance.

- The unit must be installed following the local standard, safety codes and guidelines. Please contact the seller, installer or a qualified specialists.
- Follow the instructions below or incorrect and improper use during installation can cause the loss of the warranty or parts guarantee.
- Maintenance must only be performed by qualified specialists.
- Unplug or disconnect the power supply before maintenance or accessing the internal parts of the unit.
- Do not install or use a damaged device.
- In case of malfunction, switch off the unit, unplug the power supply and return to the seller or qualified specialists.
- Dispose of the packaging material following the local environmental regulations.

Unit acceptance, handling and storage.

- At the time of the delivery, please verify the correspondence between the order and the delivery docket.
- Verify the packaging integrity and, if inconsistencies with the order, damage or discrepancies are found, they must be reported on the delivery docket and promptly signaled to the supplier and manufacturing company.
- The unit must be stored in spaces protected from bad weather with a temperature between -10°C and 55°C.
- The handling and installation of the unit must be performed with the highest attention to prevent any damage of fragile parts; these operations can be facilitated with the help of the following manual.





Recent project: Cairns Aquarium Queensland

Installation, operation and maintenance manual

Identification and receiving of the appliance

Every unit is identified with a label that is inside the unit on the electric control side. The label shows the manufacturer's data, the unit type and the serial number of the unit. Check every unit before accepting it. Be sure the packaging is not damaged or bended or broken. In case of a damaged package, open it immediately and check the contents before accepting it; check the chassis and the panels of the fancoil, the heat exchanging coil, the condensate drain pan, the filter, the proper fan rotation, all the eventual accessories. Do not refuse the shipping: please write all the damages on the shipping document and take pictures of the damages.

General warnings

This manual is part of the unit and must always be with the appliance. After removing the appliance from the packaging, be sure that there are no damages and the appliance corresponds to your order. In case of great damage: write a description of the damages on the carrier's copy of the shipping documents, take pictures of the damages, send immediately a letter to the carrier, and send a copy to your dealer and/or to the manufacturer, specifying model and serial number.

General indications

An electric connection 220-240V/1/50-60Hz and an hydraulic connection to the water chiller/boiler are necessary to allow proper working of the appliance. The unit has been designed for installation in rooms where people live, and for heating and/or cooling of such rooms; the unit must be used only for that purpose. Each unit is checked and tested in the factory, and is delivered to the customer only if properly working. All repair/maintenance operations must be carried out by qualified specialists. Failure to observe the rules contained in this manual, or any unauthorized modification / tamper of the appliance can cause dangerous situations and will immediately invalidate the warranty of the appliance. The manufacturer is not responsible in case of damages caused by:

- unauthorized changes or modifications to the appliance
- improper installation or improper use

Mandatory safety rules during installation

The fancoil must not be installed: outdoor, in a too humid environment, in explosive or corrosive environment, in a very dusty environment. A bipolar safety switch must be installed, to disconnect the appliance from the electric power supply; the switch must: be properly sized, be easily accessible and close to the appliance, have a minimum 3mm distance between its contacts. The appliance must be properly connected to an electric earth. Do not place flammable / dusty goods close to the appliance. Do not remove the labels from the inside of the appliance.

Mandatory safety rules during use, maintenance, repair

It is dangerous: to touch the fancoil with wet parts of the body and bare feet; to modify or tamper the settings of the safety devices; to spray water or flammable liquids/gas onto the fancoil; to introduce foreign objects or hands through the air intake and discharge grills; to introduce foreign objects or hands into the fans. Do not bend, pull, detach the electric wires out-coming the fancoil, even if it is disconnected from the power supply.

Before any maintenance / repair:

- disconnect electrical power source and secure in disconnected position
- close the water valves
- wait until the water is at the same temperature of the room
- wear safety gloves
- in case of replacement of components use only original spare parts supplied by the manufacturer

Before any maintenance be sure that: the unit is disconnected from the electric power source; the water valves are closed; the water temperature is not dangerous (too hot or too cold). Children or disable people must not use the fancoil without assistance. If the fancoil is installed in very cold climates, and a long un-operative period is forecasted, the hydraulic circuit must be completely emptied, in order to avoid risk of ice inside the tubes; ice will cause big damages. If a damper for external air is installed, the cold air can cause ice inside the tubes of the coil, and ice will break the tubes. If necessary, some glycol must be mixed with the water of the hydraulic circuit. The coils are tested up to 4000 kPa (40 bar). In case the air filter has to be cleaned or changed be sure it is fitted again in the appliance before re-starting the unit.



Recent project:
Toowoomba
Grand Central
Queensland

Operating limits

- Electric power supply: V220-240/1/50-60Hz
- Minimum temperature of the cooling water (without glycol): 5°C
- Maximum temperature of the heating fluid: 100°C
- Working pressure: 14,4 bar – Maximum allowed operating pressure: 24 bar

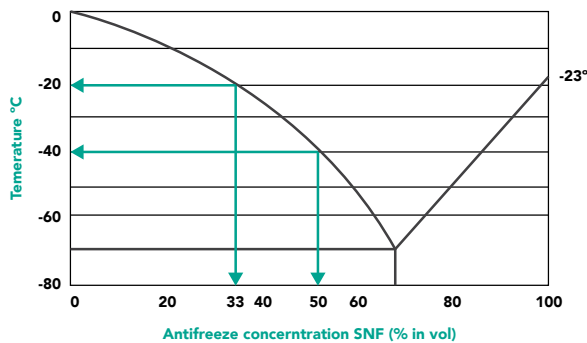

In the case of installations where the temperature can drop below 0°C, it is necessary to add glycol to the water according to the table. Ethylene glycol is used to protect the circuit from freezing, and to prevent the tubes from being broken. The following table gives the percentage of glycol to add in order to obtain a specific freezing temperature. The mix of water and glycol has a specific mass and viscosity which varies depending on the temperature and concentration; consequently this affects the capacity of the fan coil. Glycol is generally used as an inhibitor of corrosion, so it is necessary to measure its concentration at least once a year.

Dilution of 50% gives an antifreeze protection up to 40° dilution of 33% gives protection up to -20°C. Dilution of 68% gives maximum antifreeze protection up to -69°C. Dilution bigger than 70% in water are not achievable.

Glycol (%)		Freezing Temperature (°C)	Specific mass (kg/dm ³)		Specific heat (kJ/kg*K)		Increase (%)
0	0	0	0,9888	0,958	4,18	4,20	4,33
10	9,6	-4	1,000	0,970	4,10	4,12	5,00
20	19,4	-10	1,012	0,980	3,95	4,05	5,40
30	27,4	-17	1,025	0,991	3,81	3,92	5,60
34	33,4	-21	1,030	0,994	3,73	3,86	5,85
40	39,6	-25	1,037	1,000	3,60	3,78	6,20
44	43,7	-30	1,041	1,004	3,00	3,73	6,32
50	49,5	-37	1,047	1,010	3,45	3,65	6,50
52 % max	51,6	-40	1,050	1,012	3,42	3,62	6,51

Technical characteristics of the fan motor minimum cross section of the electric supply wires

Size	TOM TIM	20	25	30	35
Motor absorption	Ain	1,85	2,40	4,06	4,16
Motor Power	Win	374	540	770	860
Minimum cable section	mm ²	1,5	1,5	2,5	2,5

Size	TOM-EC TIM-EC	20	25	30	35
Motor absorption	Ain	2,25	2,08	3,68	3,76
Motor Power	Win	340	320	540	580
Minimum cable section	mm ²	1,5	1,5	2,5	2,5

	TO TI TO-DS	30	35	50	60
Motor absorption	Ain	4,06	4,16	4,90	5,60
Motor Power	Win	770	860	970	1220
Minimum cable section	mm ²	2,5	2,5	2,5	2,5

	TH TH-DS	30	35	50	60
Motor absorption	Ain	2,91	4,30	5,86	9,21
Motor Power	Win	670	990	1352	2110
Minimum cable section	mm ²	1,5	2,5	2,5	2,5

Size	TO-EC TI-EC TO-DS-EC	20	25	30	35	50	60
Motor absorption	Ain	2,25	2,08	3,68	3,76	3,86	5,86
Motor Power	Win	340	320	540	580	610	1080
Minimum cable section	mm ²	1,5	1,5	2,5	2,5	2,5	2,5

Data shown in the following tables are valid only for the fan motor and do not include any accessory, i.e. valves or electric heaters.

- The cross sections of the wires that are shown in the following tables are: the minimum required to connect the fancoil to the electric supply, valid for wires maximum 10 m long, valid for a maximum current load 5 A/mm², valid only for the fan motor and DO NOT include any accessory (valves, electric heaters, pumps, controls, etc.), valid only for copper wires.

- The voltage drop between operating and non-operating unit must remain below 3%; if the voltage drop is greater than 3%, a bigger wire is required.
- Minimum cross section of the wires 1,5 mm².

Electric heaters v230/1/50-60hz

Tube INOX AISI 304L – Fins Fe/AlZn -Rules DPR 547/55 – CENELEC EN60 - IEC 335.1 - CEI 61-50

Each power element	W (±5%)	700	1000	1200	1500	2000	2500	3000	4000	5000
Active length	L [mm]	350	350	550	750	750	950	1150	1350	1550
Current absorbed	[A]	3,1	4,5	5,5	6,6	9,0	11,0	13,0	18,0	21,7
Thermic charge	[W/cm ²]	4,3	6,0	4,4	4,0	5,3	5,1	5,0	5,7	6,2

Mechanical installation

Choose an area that can allow a proper circulation of the air, both incoming to and out-coming from the fancoil. Do not place any curtain or any object that can obstruct the unit air outlet and return. Adequate clearances around the fancoil are necessary to allow easy access for maintenance and cleaning operations. The fancoil must be mounted level, to assure proper operation and drainage. Level the fancoil by adjusting the hanging rods; level the unit by checking on the unit casing. Do not use the coil or drain pan for leveling, as they are pitched to provide proper drainage. Use shock absorbers supports, to avoid transmission of noise and vibrations through the walls. Put shock absorbers between the unit and the air ducts (both return and supply sides), to avoid transmission of noise and

vibrations through the ducts. Do not install the fancoil where water dripping inside the appliance may happen. Before installation, be sure that electrical and hydraulic connections are on opposite sides of the appliance or that electric board is adequately protected with IP55 box. For dimensions and weights of the unit please refer to the catalogue or to the data sheet of each unit. Below a table showing positions of hanging holes for wall mounted, ceiling or ducted fancoil and the duct connection to return and supply side.

For ducted units on supply side it is possible to connect duct with self-tapping screws on supply frame, on return side it is possible to connect duct with self-tapping screws on filter frame.

Hanging on the wall / ceiling

**TOM / TOM E-C
TIM / TIM E-C
TO / TO-EC
TI / TI-EC
TH**

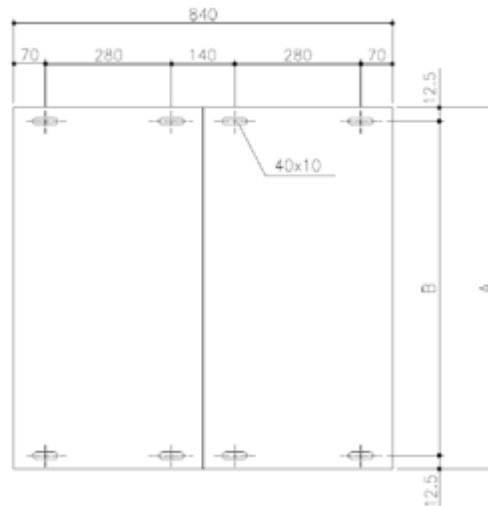

	20	25	30	35	50	60
A	1000	1200	1400	1600	1800	2000
B	975	1175	1375	1575	1775	1965

**TO-DS 20-25-30-35 / TO-DS-EC 20-25-30-25
TH-DS 20-25-30-25**

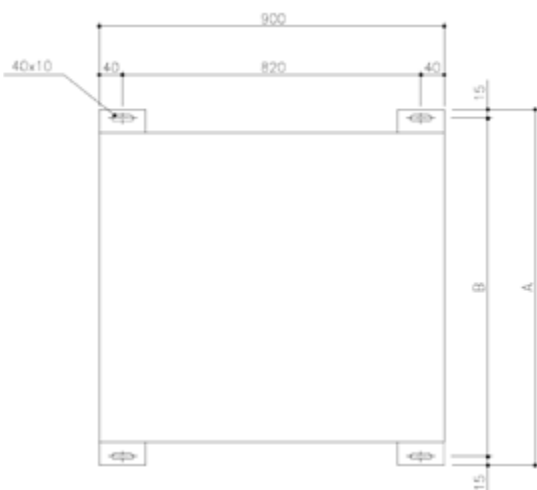

**TO-DS 50-60 / TO-DS-EC 50-60
TH-DS 50-60**

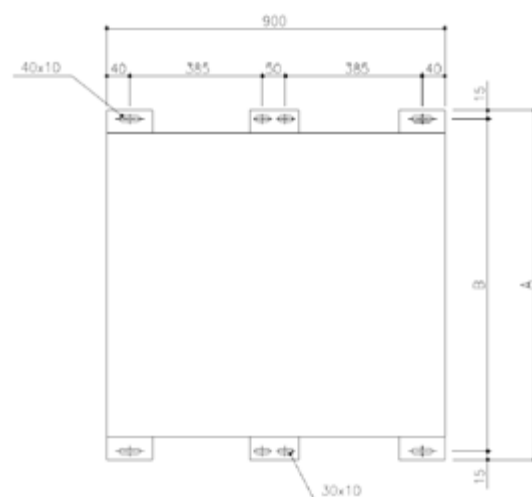

	20	25	30	35	50	60
A	1000	1280	1480	1680	1880	2080
B	1050	1250	1450	1650	1850	2050

Supply / return duct connection

MANDATA

TO / TO-EC

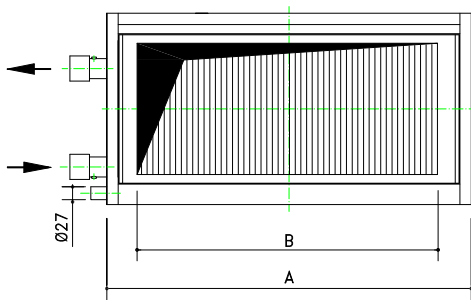

TO-DS / TH-DS / TO-DS-EC

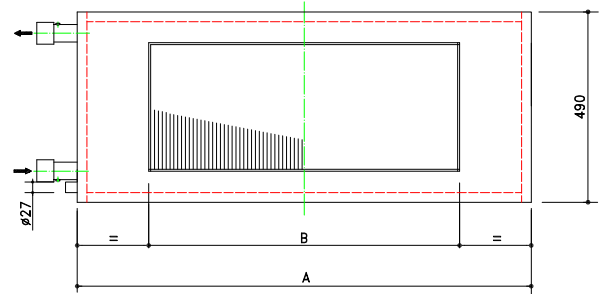

	20	25	30	35	50	60
A	1000	1200	1400	1600	1800	2000
B	800	1000	1200	1400	1600	1800
C	1000	1200	1400	1600	1800	2000
D	800	1000	1200	1400	1600	1800

RIPRESA



	20	25	30	35	50	60
A	990	1190	1390	1590	1790	1990
B	954	1154	1354	1554	1754	1954

Hydraulic connections

Proper hydraulic connections and proper circulation of the water inside the circuit assure: good operation and long life of the appliance, limited energy consumption. The piping must be: properly sized (proper diameter); properly insulated, to avoid condensate dripping and heat dissipation. In general, the water inlet is in the lower part of the coil; the water outlet is in the upper part of the coil. When valves and/or stop valves are mounted, due to space constraints it may be necessary to put the water inlet in the upper side and the water outlet in the lower side of the coil. Allowed materials for the condensate drain piping are: PVC or steel. In any case, after the piping has been connected to the unit, tape sealant must be used to prevent water leakages.

Before installing the fancoil, read carefully the warnings and the safety rules be sure the water inside the circuit is filtered, free from scale or iron oxides, that can damage the heat exchanging coil and the valves. If necessary, water must be treated with chemical agents, in order to prevent: creation of scale, corrosion, growth of algae, creation of sludge. To connect the heat exchanging coil to the water circuit: always use two spanners; be careful and avoid any damage to the copper tubes of the coil. Always fit two gate valves on the water circuit: one valve on the water inlet of the fancoil, and one valve on the water outlet.

Drain pan discharge

Create a drain trap; create a minimum slope 50 mm/m; do not create counterslopes; do not flatten or kink the pipe; check the connection by pouring water into the drain pan. Check the circuit: give hydrostatic pressure, air vent the coil of the unit, be sure that no dripping occurs. Do not check the circuit just before a holiday: big troubles may occur if qualified control personnel is not on duty.

- It is indispensable to install a siphon on the drain line to prevent the fan sucking obnoxious odours or bacteria from the drain system, creating ideal condition inside the fancoil unit for the proliferation of pathogenic germs and micro-organisms, also favouring the diffusion of Legionella Pneumophila responsible for Legionnaires' disease.
- A drain connection without a siphon, or with an incorrectly installed siphon, allows air to be sucked into the unit, the condensate cannot drain and is carried over into the next section of the unit and the condensate will spill out of the unit, flooding the surrounding area, when the fan is shut down.
- The siphon must not be hermetically connected to the drain line to permit air locks to be broken.
- A siphon in positive pressure must never be connected to another in negative pressure.
- The drain line downstream of the siphon must have sufficient slope to carry away the condensate and its diameter should be at least the same as the unit drain connection.
- The drain piping can be in various materials: steel, copper, PVC.
- If the drain line is improperly supported it may deform, create air locks and prevent proper drainage of the condensate.
- It is good practice to insulate the siphon and drain line to prevent the formation of condensate on the outside of the piping. In winter antifreeze should be added to the water in the siphon.
- Beware of evaporation of the water in the siphon during shut down periods. The maintenance personnel should ensure that the siphons are always full.
- The siphon should be equipped with an inspection plug in an easily accessed position.
- The condensate drain pan should be cleaned periodically to avoid stagnant condensate, formation of algae and scale.

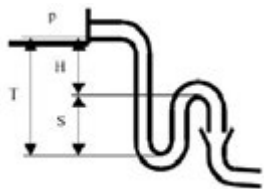

Drain in positive pressure

$$T = 2 p S = T / 2 H = T - S$$

Example

$$P = 400 \text{ Pa} = 40 \text{ mmwc}$$

$$T = 80 \text{ mm} - S = 40 \text{ mm} - H = 40 \text{ mm}$$

Drain in negative pressure

$$T = - 2 p S = T / 2 H = T - S$$

Example

$$P = - 250 \text{ Pa} = - 25 \text{ mmwc}$$

$$T = 50 \text{ mm} - S = 25 \text{ mm} - H = 25 \text{ mm}$$

Electrical connections

Before installing the fancoil, read carefully the warnings and the safety rules. Electrical connections must be made only by qualified personnel, and must accomplish the local electrical and safety codes and ordinances. A bipolar safety switch must be installed, to disconnect the appliance from the electric power supply; the switch must: be properly sized, be easily accessible and close to the appliance have a minimum 3 mm distance between its contacts. All electrical connections are to be made in accordance with local electrical and safety codes and ordinances. The fancoil must be properly earthed; make earth connection prior to any other electrical connection. For wiring and installation, refer to the wiring diagram of the fancoil, that are fitted on each unit and shown in this manual. Accessories that are not described in this manual require separate power supply; all power supplies must be properly protected with switches and fuses.

Be sure the voltage is inside the allowed limits: see Operating Limits and Technical Characteristics. Be sure the electrical circuit upstream the appliance is properly sized to carry the current that is necessary to operate the fancoil (see Technical Characteristics) and all the other devices already installed or forecasted. Minimum cross section of the wires 1,5 mm². Wires to the auxiliary circuits (switches, controls, interlocks, etc.) must have 1,5 mm² minimum cross section. Choice proper cross section of the wires: current must be limited to 5 A/mm²; voltage drop between not-operating and operating unit must be limited to 3%.

Motor wiring

The fancoil has a terminal block that is mounted on the internal side panel on the opposite side to the hydraulic connections. The terminal block is ready to be connected to the fan speed selector switch or to the thermostats. Both the fan speed selector switch and the thermostats are supplied as accessories, and their connection to the unit is shown in the installation instructions supplied with them. After the wires have been inserted in the terminal block, tighten the screws on each terminal, to assure a good electric contact. Failure to accomplish this requirement may cause serious danger and possibility of fire.

Start-up

After the installation or maintenance, make the following checks before starting the unit:

- Fan rotates freely
- Piping connections completed
- Power supply voltage inside the operating limits
- Condensate drain pan free of construction debris
- Air vent completed
- Duct connections completed (ducted units only)
- Drain lines clean and operating
- Water pressure inside operating limits
- Filter is free of construction debris
- Drain lines with proper slope, without counter-slope and restrictions
- Adequate cross section of electrical wires
- Air return flow is free of obstacles and obstructions
- Condensate drain water evacuates properly
- Electrical connections completed and tightened
- Air delivery flow is free of obstacles and obstructions
- Adequate cross section of water pipes

Filter

The function of the air filter is to remove foreign matter such as dirt, soot, pollen, and other impurities from the air passing through it. Said impurities may enter into the fancoil and damage it. The filter should be replaced once a year; the filter should be replaced more frequently if the fancoil is used in a very dirty or dusty environment. Between one replacement and the next one, the filter has to be kept clean. A dirty filter does not filter the air passing through it, and: impairs the operating efficiency of the unit by restricting the air flow over the coil; encourages the growth of bacteria that may be dangerous to the health. To clean the filter, please operate as follows: remove the filter from its operating position, clean the filter using a vacuum cleaner, if the filter is too dirty and it's impossible to clean it, the filter must be replaced with a new one. Filter is kept in position by clips (see photo), rotate the clips to extract the filter.

For vertical units and horizontal units without filter frame simply rotate the clips and extract the filter, for units with filter frame rotate the clips and extract the filter which will slide down. After cleaning the filter place it back in its operating position.



Condensate drain pan

The condensate drain pan must be checked before the beginning of the cooling season. The condensate drain pan and the discharge hole may clog with scale; remove scale with proper chemical products. The condensate drain pan may collect dirt that falls from that coil and, in case of vertical installation, may contain foreign materials that fall into the fan coil passing through the air delivery grill. Dirt and scale that are cumulated in that drain pan may impair the evacuation of condensate water, so causing water coming out from the unit. To clean the condensate drain pan, operate as follows: remove the drain pan from its operating position, clean the drain pan with fresh water, wipe the drain pan carefully, place the drain pan back in its operating position.

Heat exchanging coil

If the air filter is properly cleaned, the coil does not need any maintenance. Use a vacuum cleaner in case that coil need to be cleaned. If the coil is very dirty, brush between fins with a stiff nylon brush.

Be very careful, to avoid any damage to the fins of the coil if the coil remains dirty, or makes a bad smell, ask a specialized technician for proper cleaning and maintenance.

Fan and fan motor

Maintenance of the fan and the fan motor must be carried out only by specially trained people. No attempt should be made to lubricate these permanently lubricated motors: the motor may be clogged by sludge.

At least once a year the following operations must be carried out: remove dust and dirt from the inside of the scroll; be sure the fan is properly fixed to the motor and is well balanced. The fan motors do not require any maintenance, as they are permanently lubricated.

Electrical connections

At least one a year, be sure the screws of the terminals are well tightened.

The motor does not rotate at all, or does not rotate properly

Electrical connections are wrong, are not according to the wiring diagrams

The fan speed selector switch (if installed) is in a wrong position

The seasonal changeover switch (if installed) is in a wrong position

The setting of the thermostat (if installed) is wrong

The fancoil does not cool / heat properly

No water coming to the fan coil

The filter is dirty / clogged

The heat exchanging coil is dirty / clogged

There is some air into the water circuit

The fan does not rotate at all, or does not rotate properly

Water comes out from the unit

No electrical power coming to the fan coil

There are some leakages from the hydraulic connections

The condensate drain pan is dirty, or the discharge hole is clogged

The condensate piping has a wrong slope, or the slope is not enough

The condensate piping is clogged

Waste disposal

Packaging, consumables, replaced parts must be disposed according to the local safety laws and environmental protection laws.

Technical data shown in this booklet are not binding. Manufacturer shall have the right to introduce at any time whatever modifications deemed necessary to improve the product.



Motor wiring

The fan coil has a terminal block that is mounted on the internal side panel on the opposite side to the hydraulic connections. The terminal block is ready to be connected to the fan speed selector switch or to the thermostats.

Both the fan speed selector switch and the thermostats are supplied as accessories, and their connection to the unit is shown in the installation instructions supplied with them. After the wires have been inserted in the terminal block, tighten the screws on each terminal, to assure a good electric contact. Failure to accomplish this requirement may cause serious danger and possibility of fire.

Terminal Description	
1 - HIGH	Black
2 - MEDIUM	Brown
3 - LOW	Red
4 - COMMON	Blue
T - EARTH	Yellow - Green
X1	Terminal Block

VARIANT 01-2003
V230/1/50-60Hz

Attention:

Each fan has its own built in motor - in case of multi fans, motors are wired in parallel in the factory and cables are connected to the external; electric terminal box X1

Warning:

All equipment that requires earth connections must be wired to the earth

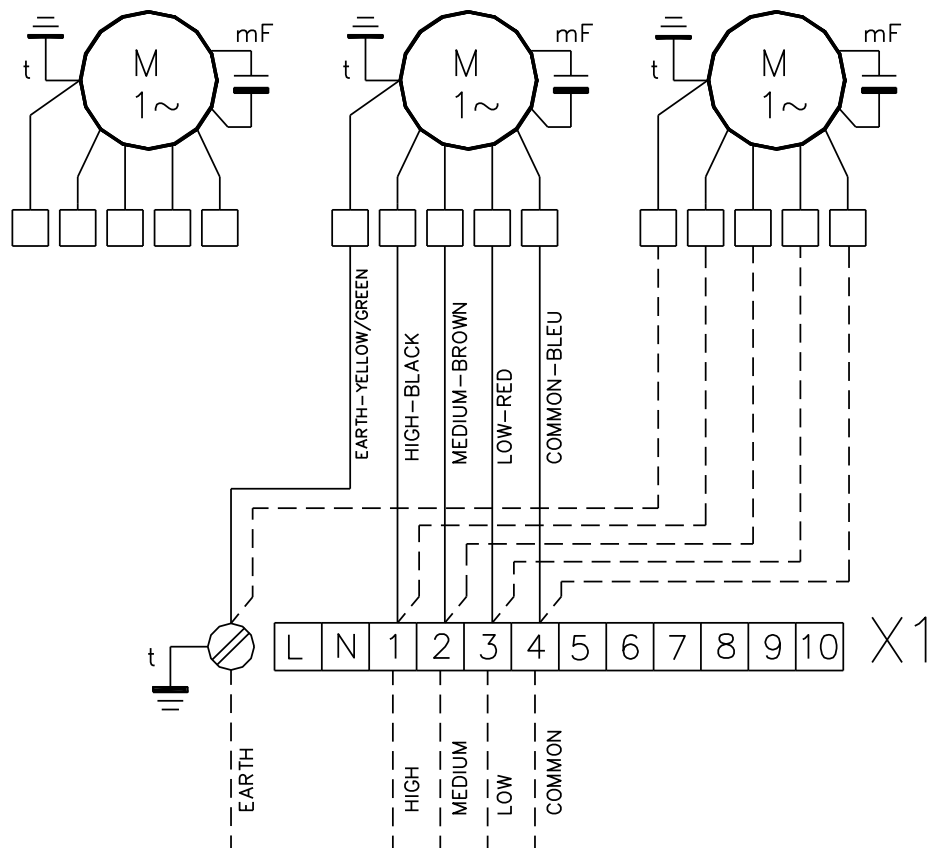

Wiring diagram with 1 / 2 / 3 EC motors For TE-DS series [H515]

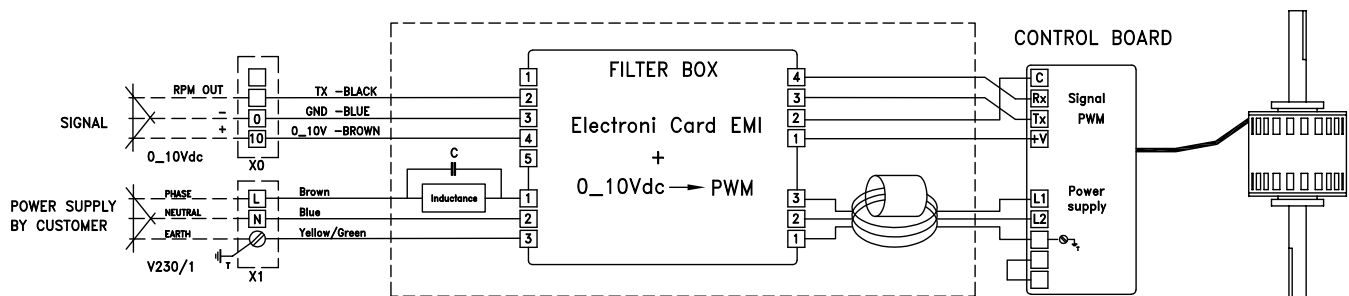

SIZE	MOTOR NR.	HP
20	A	1/3
30	A	1/2
60	A+B	1/2 + 3/4

Attention:

Each fan has its own built in motor - in case of multi fans, motors are wired in parallel in the factory and cables are connected to the external; electric terminal box X1

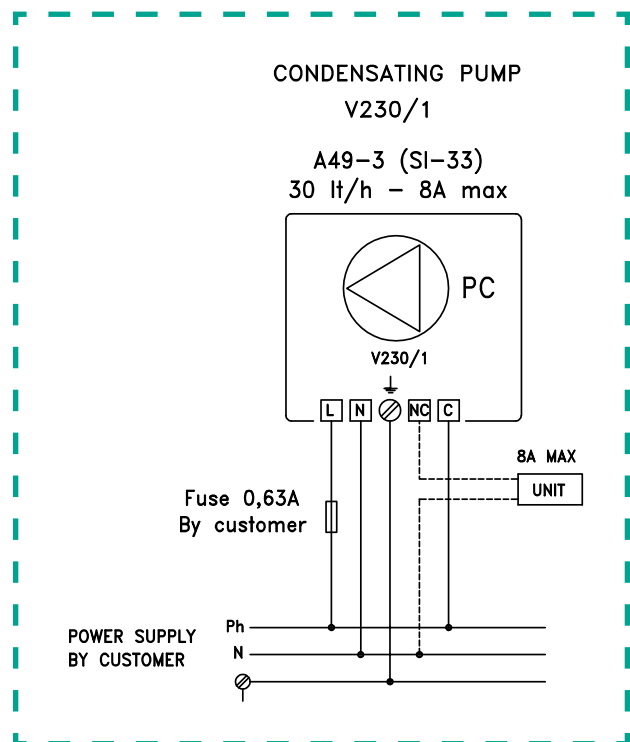

--- Optional condensate pump

Wiring diagram with 1 / 2 / 3 EC motors For CE-DS series [H515]

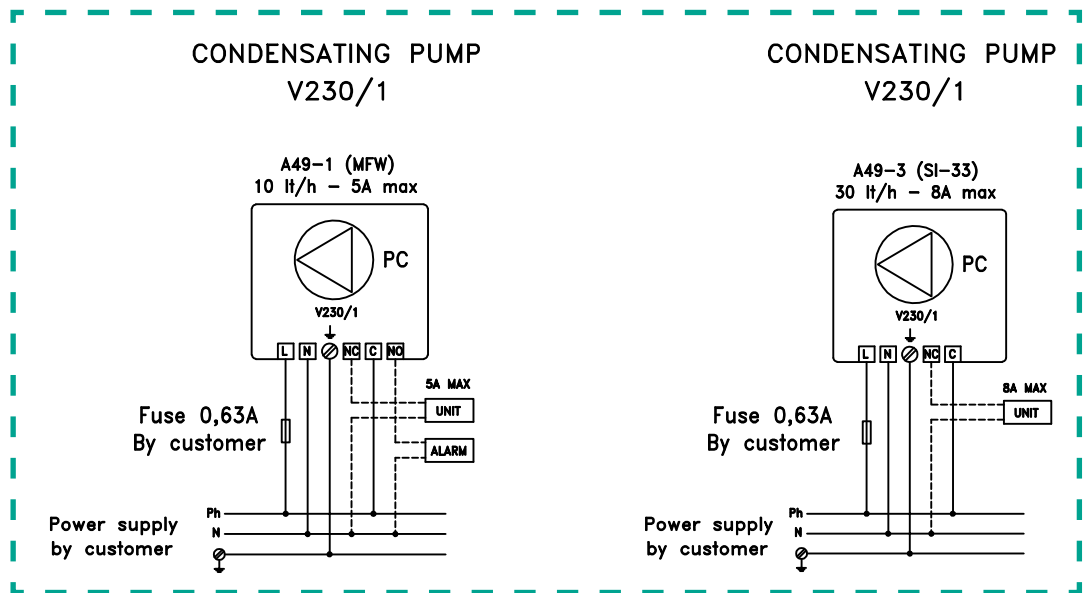
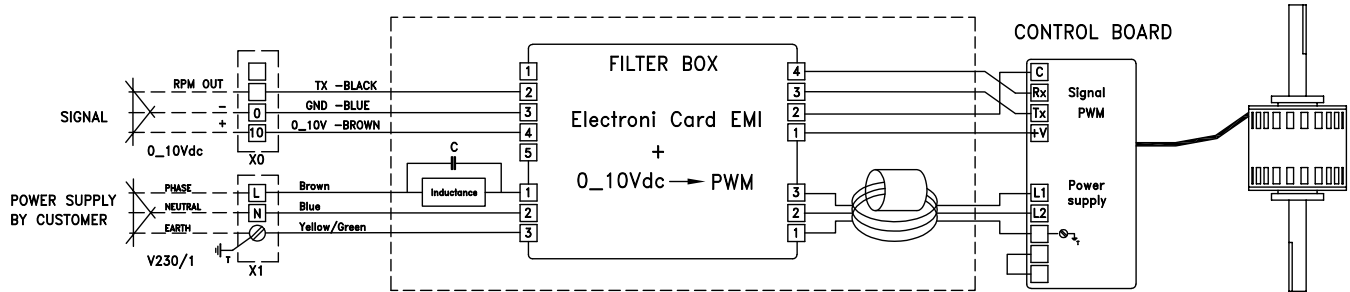

Optional condensate pump

SIZE	MOTOR NR.	HP
09	A	
11	A	
17	A	
20	A	
23	A+B	
32	A+B	

Attention:

Each fan has its own built in motor - in case of multi fans, motors are wired in parallel in the factory and cables are connected to the external; electric terminal box X1

Wiring diagram for EC motor For FH-DS-EC series

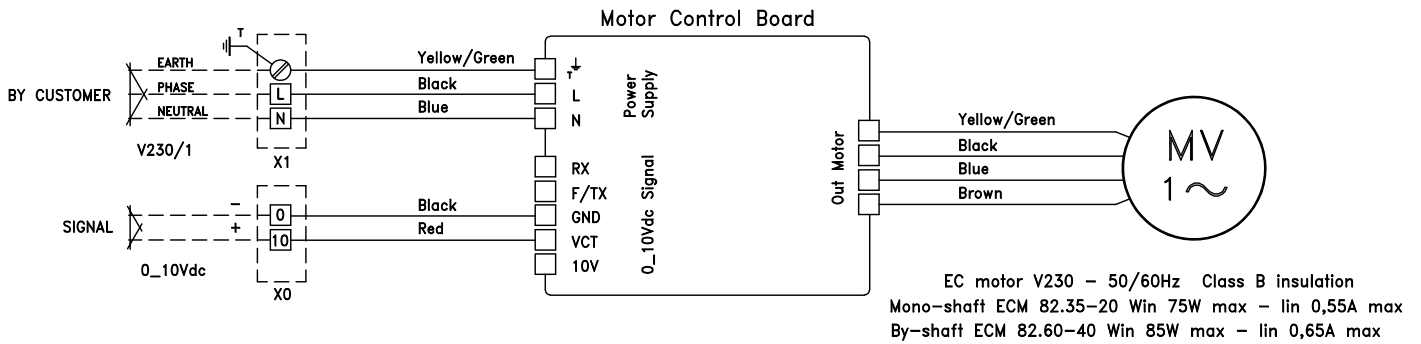

SIZE	MOTOR NR.	HP
025	A	
035	A	
050	A	
070	A	
090	A+B	

Attention:

Each fan has its own built in motor - in case of multi fans, motors are wired in parallel in the factory and cables are connected to the external; electric terminal box X1

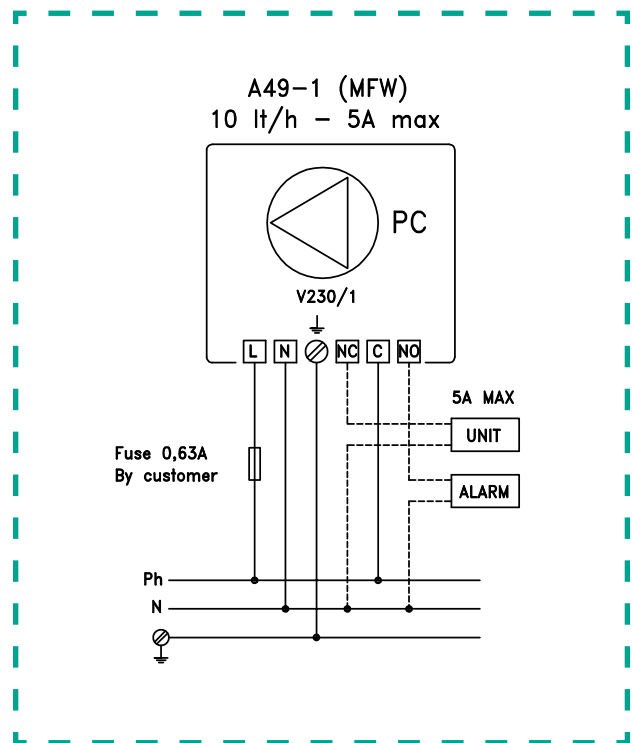

Optional condensate pump

Recent projects

Cairns Aquarium
Queensland



Christchurch
Entertainment
Centre
New Zealand



Apple Store
New South Wales



Travel Lodge
New South Wales



Australian
Federal Police
Queensland



Toowoomba Grand
Central
Queensland



ENGINEERED
HVAC SOLUTIONS



oceania
SOLUTIONS GROUP

For more information on our latest projects, visit www.oceania-group.com

PO Box 429
Cannon Hill QLD 4170
info@oceania-group.com

www.oceania-group.com

Click to follow
our socials



Wiring diagram with 1..2 - EC motor for to - EC series

SE3667

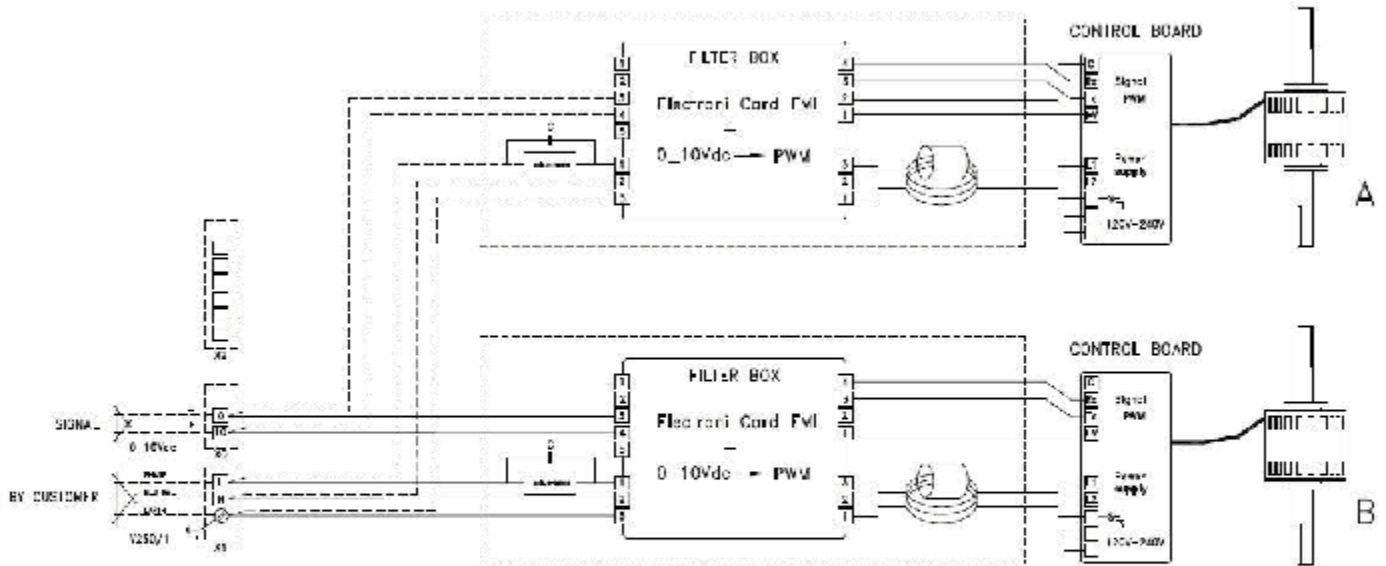

SIZE	MOTOR NR.	HP
20	A	1/3
25	A	1/3
30	A	1/2
35	A	3/4
50	A+B	1/3 + 1/2
60	A+B	1/2 + 3/4

Attention:

Each fan has its own built in motor - in case of multi fans, motors are wired in parallel in the factory and cables are connected to the external; electric terminal box X1

TO-EC Base 2M
10.2015